

Research Article

A Compact Gas-Cooled Fast Reactor with an Ultra-Long Fuel Cycle

Hangbok Choi, Robert W. Schleicher, and Puja Gupta

General Atomics, P.O. Box 85608, San Diego, CA 92186-5608, USA

Correspondence should be addressed to Hangbok Choi; h.choi@ga.com

Received 24 October 2012; Accepted 14 March 2013

Academic Editor: Wei Shen

Copyright © 2013 Hangbok Choi et al. This is an open access article distributed under the Creative Commons Attribution License, which permits unrestricted use, distribution, and reproduction in any medium, provided the original work is properly cited.

In an attempt to allow nuclear power to reach its full economic potential, General Atomics is developing the Energy Multiplier Module (EM²), which is a compact gas-cooled fast reactor (GFR). The EM² augments its fissile fuel load with fertile materials to enhance an ultra-long fuel cycle based on a “convert-and-burn” core design which converts fertile material to fissile fuel and burns it in situ over a 30-year core life without fuel supplementation or shuffling. A series of reactor physics trade studies were conducted and a baseline core was developed under the specific physics design requirements of the long-life small reactor. The EM² core performance was assessed for operation time, fuel burnup, excess reactivity, peak power density, uranium utilization, etc., and it was confirmed that an ultra-long fuel cycle core is feasible if the conversion is enough to produce fissile material and maintain criticality, the amount of matrix material is minimized not to soften the neutron spectrum, and the reactor core size is optimized to minimize the neutron loss. This study has shown the feasibility, from the reactor physics standpoint, of a compact GFR that can meet the objectives of ultra-long fuel cycle, factory-fabrication, and excellent fuel utilization.

1. Introduction

Nuclear power has much to offer in addressing the nation's energy security needs in an environmentally acceptable manner. However, today's nuclear power has its own challenges in the management of nuclear waste from both the front end and back end of the fuel cycle, along with huge upfront financial investment and competing against other energy resources—electricity generation cost. Currently, the most prevailing commercial reactor type is the Light Water Reactor (LWR), and it is expected that the advanced LWR will be introduced in the very near future based on proven technologies [1]. However, the International Atomic Energy Agency (IAEA) predicts that for the longer term the focus will be on innovative designs to provide increased benefits in terms of safety and security, nonproliferation, waste management, resource utilization, and economics, as well as to offer a variety of energy products and flexibility in design, siting, and fuel cycle options [2].

Small reactors are defined as reactors with an equivalent electric output of less than 300 MW. The small modular

reactor has been developed since the 1950s when the United States (US) Army and Navy initiated research programs for the design and test of various small nuclear reactors [3]. The Army was interested in producing electricity in remote area, which included a transportable reactor by tractor trailer without dismantlement and a barge reactor transportable by sea. The Navy focused on development and deployment of nuclear power sources for warships and submarines. In 2008, more than 45 small- and medium-sized reactor concepts and designs were developed under the national or international Research and Development (R & D) programs [4].

Though it is difficult for small reactors to compete economically under the same paradigm as large commercial reactors, the market situation of the small reactors will be different from those of large-capacity nuclear power plants. In other words, it will depend on demand for a better distributed electricity supply, better match between the capacity increment and investment, and flexibility in site selection or diversity of the products [5, 6]. The IAEA addressed attractive features of innovative small reactors that might facilitate their

progress in certain energy markets as follows:

- (i) factory fabrication that reduces cost, shortens construction time, and improves quality control; reduced design complexity, impact of human factors, and operation and maintenance requirements;
- (ii) lower absolute capital costs, as compared to large capacity plants; incremental capacity increase with sequential construction; reduced financial risk for the incremental increase of demand;
- (iii) suitability for small electricity grids, including an option of autonomous operation; feasible nonelectric applications such as seawater desalination, district heating, and process heat;
- (iv) improved safety due to smaller core size.

In addition, small reactors with a longer fuel cycle can further improve the plant economy and energy security. The potential incentives of long-life small reactors will be the reduced obligations for spent fuel and waste management and greater or easier nonproliferation assurances to the international community [7]. Many countries such as the USA, the Russian Federation, Japan, India, and Brazil have performed design studies of small reactors without refueling, which include water, sodium, lead-bismuth and gas-cooled reactors [8–14]. The liquid metal reactors have shown good performance of long-life operation because of a high conversion ratio and neutron yield owing to hardened neutron spectrum and transuranic fuel, respectively [15–17]. It is also possible to design a traveling wave type sodium-cooled fast reactor with a capacity of 1000 MW electric, which can last more than 30 years with a single initial fuel loading [18].

General Atomics launched an innovative new gas-cooled fast reactor (GFR) program in 2009, named Energy Multiplier Module (EM²). The reactor system is designed to have dual applications: electricity generation and high temperature heat source. The reactor is small and transportable and can be deployed in an established grid or as a stand-alone power source for an isolated area or a military base. The reactor will be operated for decades without refueling. The reactor core is designed to use nonradioactive nuclear waste, that is, depleted uranium (DU), along with low enriched uranium (LEU). This paper describes the physics design approaches and fuel cycle characteristics of the EM².

2. Design Approach and Tools

2.1. Design Choices. The design choices and their linkage to cost factor are schematically shown in Figure 1. For the high temperature operation and high quality heat source, a gas coolant such as helium is most feasible. When compared to other coolants such as sodium, the helium coolant is inert, single phase, nonradioactive, and chemically stable against water, and no intermediate loop is required for thermal-to-electric energy conversion [19]. High temperature operation improves the thermal efficiency of the plant, which has a direct effect on the electricity generation cost; however, it requires use of high temperature material for the fuel and core structure.

Both the thermal and fast neutron spectrum reactors are feasible for the gas coolant. From the physics design viewpoint, it is recommended to maximize the fuel burnup to improve the fuel cycle economics with a reasonable amount of fissile material in the core. From this perspective, a fast neutron spectrum was chosen, under which fertile fuel can be converted into fissile fuel and burned in situ. All the actinides are effectively burned or transformed under the fast neutron spectrum, while fissile nuclides are mostly burned under the thermal neutron spectrum. To accommodate high fuel burnup, the fuel design should consider high irradiation swelling of the fuel, internal pressure buildup of the fuel rod due to fission gas release, material damage due to high energy neutrons, and so forth.

Both the small and large reactor options are feasible for the gas-cooled fast reactor, while the gas-cooled thermal reactor in general requires large moderator volume which results in a low power density of the core. From the economics viewpoint, small reactors mitigate financial risk owing to low upfront capital investment, and economic competitiveness can be achieved through a modular construction approach, moving a large portion of the construction work from site to factory, shortened site construction period, design simplification, and so forth. In order to achieve an ultra-long fuel cycle in the small reactor, high quality reflector materials are required to minimize the neutron loss and the core configuration needs to be optimized to maximize the fuel utilization.

2.2. Convert and Burn. The excess reactivity of the EM² core is driven by the balance of fissile isotopes and fission product poisoning. Initially, the core is loaded with only uranium fuel, and therefore, fissile uranium produces most of the reactor power and burns quickly until fissile plutonium builds up. Under a very hard neutron spectrum, fertile uranium can also burn as shown in Figure 2. In fact, the amount of fertile fission is around 20% in the GFR which is a nonnegligible contribution to the excess reactivity of the core [20]. However, this also indicates that neutron spectrum softening significantly affects the fertile uranium fission contribution because of its high fission cross-section threshold around 1 MeV. Figure 3 compares the production-to-absorption cross section ratios ($\nu\sigma_f/\sigma_a$) of major nuclides. It can be seen that the nuclear properties of fissile plutonium are strongly dependent on neutron energy. A harder neutron spectrum will lead to higher excess reactivity; this excess reactivity decreases as fission products build up during long-life operation.

2.3. Physics Tools and Models. For the physics design calculations, a lattice code MICROX is used to generate multi-group cross-sections of the fuel and structural materials [21]. MICROX is an integral transport theory flux spectrum code which solves the neutron slowing-down and thermalization equations for a two-region (particle and moderator) lattice cell. The nuclear data of MICROX consists of GAM data (99 groups between 14.9 MeV and 0.414 eV) and GATHER data (101 energy mesh points below 2.38 eV) for the fast and thermal energy ranges, respectively [22, 23]. For the

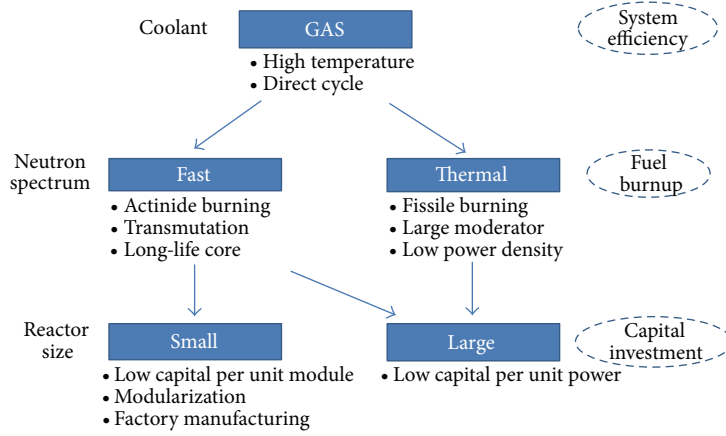

FIGURE 1: Design choices and economic factors.

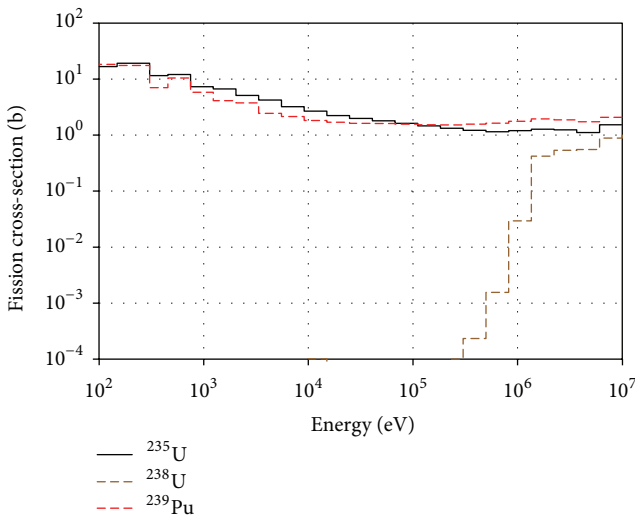

FIGURE 2: Fission cross-sections.

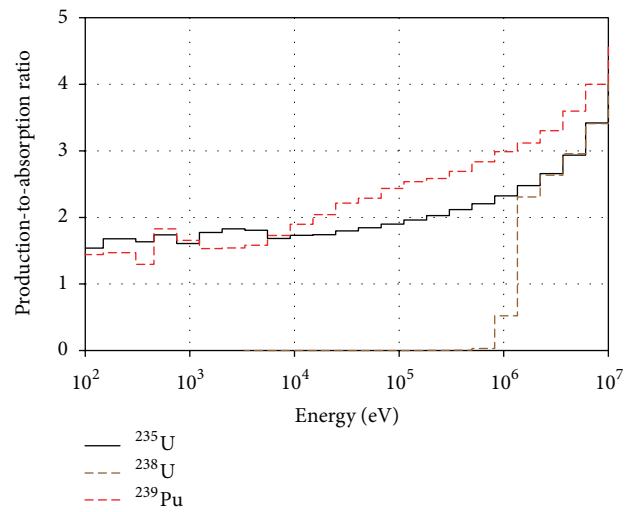

FIGURE 3: Production-to-absorption ratio.

epithermal resolved energy range, the spectrum calculation uses GAR data with temperature-dependent cross sections [24].

The reactor core is analyzed by DIF3D and BURP for the static and depletion calculations, respectively [25, 26]. DIF3D is a multigroup steady-state neutron diffusion and transport code, which is used to calculate the eigenvalue (criticality) and power distribution of the core and to generate the neutron flux distribution to be used for the depletion calculation. The BURP code is also used to produce macroscopic cross sections of each core region using the microscopic cross sections and nuclide number densities, which are used by DIF3D for static diffusion calculations.

The actinide depletion chain used in the calculations is based on 20 nuclides and includes neutron capture, $(n, 2n)$ reaction, and decay chains. Fission product yields have been generated for the fast reactor system based on JENDLE3.3 [27]. These yield data are available for ^{232}Th , ^{233}U , ^{235}U ,

^{236}U , ^{238}U , ^{237}Np , ^{239}Pu , ^{240}Pu , ^{241}Pu , ^{242}Pu , ^{241}Am , and ^{243}Am . For example, direct yield data are provided for 1227 isotopes for 1 MeV neutron fission of ^{235}U . In order to obtain cumulative fission product yield, the decay chain has been prepared for ~800 isotopes for which the direct yield is greater than 10^{-10} . The cumulative fission product yield has also been generated for 61 nonsaturating fission products (NSFP), and pseudofission products (PFP) were introduced to minimize the loss of fission products due to the truncated burn-up chain. The properties of PFP were obtained from an ORIGEN2.2 calculation [28].

The EM² core is designed to release gaseous fission products in order to achieve a very high fuel burnup. Considering that the operating temperature of the reactor is high, it was assumed that not only the noble gases (Krypton and Xenon) but also other nuclides with a relatively low boiling temperature ($<450^\circ\text{C}$) are released during normal operation. For the physics design study, it was assumed that 70% of

gaseous fission products are removed. The NSFP also contains gaseous fission products; the effective number densities for these materials were calculated by considering the reduction of absorption rate due to fission gas removal. The amount of gaseous fission products in the NSFP is 6%–8%. If the removal rate of gaseous fission products is 70%, for example, the inventory of saturating fission products and NSFP is reduced by 9.0% and 6.5%, respectively, at the end-of-cycle, resulting in a 7.2% reduction of total fission product inventory [29].

The adequacy of using the legacy code system for the EM² core depletion calculation was assessed in the earlier study especially for the prediction of peak excess reactivity and fuel cycle length [29] by the Monte Carlo code MCNPX with ENDF/B-VII.0 cross sections [30]. In general, the core excess reactivity is well predicted by the diffusion-based depletion model except for the initial core state where the maximum difference is 0.5% δk . The differences of the peak excess reactivity and cycle length are less than 0.2% δk and 2 years, respectively. Currently the legacy code system is being updated for its cross section library and solution methods [31, 32].

3. Physics Design Requirements

A particular feature of EM² physics design is that it aims for an ultra-long fuel cycle and a very high fuel burnup with a small reactor core size so that the fuel utilization is dramatically increased when compared to a commercial LWR. The principal requirements that guided the initial nuclear design studies are as follows.

- (i) The nuclear reactor system shall have a design life of more than 20 years to enhance a high uranium utilization and fuel cycle economics.
- (ii) There will be no refueling and fuel shuffling during the core life, and therefore, there will be no movement of either fresh or spent nuclear fuel materials to/from the reactor core.

Scoping analyses indicated that a heterogeneous core configuration is more favorable to obtain a longer fuel cycle when using fertile fuel. Therefore, the core will be composed of two distinctive fuel materials: the fissile starter (LEU) and fertile converter (DU). In order to fulfill the principal design requirements, the fissile enrichment, location, and size of the starter have been optimized under the physics design requirements given below.

3.1. Reactor Size. The reactor core size shall be limited by the maximum size of the reactor vessel that can be manufactured by competitive US fabricators and transported through special overspecified routes by special permit. The reactor vessel shall be sized to allow truck transport from the factory to the designated site. The reactor vessel shall be sized to include reactor core, reflector material, radiation shield, thermal shield, instrumentation, and control system. A guideline for maximum vessel size is 250 tons for component mass, 4.8 m

for component diameter, and 30 m for component length, respectively.

3.2. Reactor Power. The reactor produces high temperature heat through controlled fission reactions in the fuel and regulates the rate of heat production to maintain a constant coolant outlet temperature in response to changes in coolant mass flow rate. The total reactor power is 500 MW thermal, and the core outlet temperature shall be 850°C. The power profile shall be flattened to reduce the peak fuel temperature. The fuel assembly peak power density shall be less than 200 W/cm³ throughout the core life.

3.3. Fuel Management. The reactor operation time shall be maximized to enhance maximum overall fuel burnup. During the core life, the magnitude of excess reactivity shall be within the reactivity worth of the reactor control system with a sufficient margin, and the peak power density shall be kept below the 200 W/cm³ design limit. The initial fissile enrichment averaged over the whole core including both the starter and converter fuel assemblies shall be minimized with a goal of overall enrichment close to that of the conventional LWR fuel. The plant life shall be at least 60 years and the fuel life shall be greater than 20 years at rated power without refueling or reshuffling.

3.4. Reactor Control System. The reactor core includes reactivity control systems that consist of multiple control drums strategically located in the reflector region and operating in banks. The reactor control system provides overall reactor power level and excess reactivity control. The reactor control system shall be designed to provide enough negative reactivity to maintain the controlled criticality of the core.

3.5. Reactor Shutdown System. The reactor core includes shutdown systems that are independently and adequately activated to rapidly shut down the reactor core under postulated accident conditions. The static and dynamic reactivity worth of the shutdown system shall be sufficient to terminate the reactivity and power transient following a reactor trip in response to a reactivity excursion accident such as a loss of coolant.

4. EM² Physics Performance

The baseline core was selected through a series of parametric calculations of key design parameters: reactor size, fuel material type, matrix material type, fuel volume fraction, starter size and enrichment, reflector material and thickness, and so forth. The physics design calculations also incorporated some of the fuel and thermal-fluid design features such as fuel material chemical reaction, compatibility of the fuel material with clad, and cooling capability of the fuel. The baseline core model provides fundamental physics design values of EM² so that follow-up calculations are performed for the fuel performance, reactor safety, and economics analyses.

4.1. Baseline Core Model. The major components of the reactor system and coolant flow are shown in Figure 4. The reactor vessel is an internally insulated 4.7 m diameter, 10.6 m high structure constructed from standard SA533-Grade B plate steel. This vessel is of a size that can be manufactured by many vendors and is small enough to be shipped by truck to the construction site.

The EM² baseline core, schematically illustrated in Figure 5, has a cycle length greater than 30 years without refueling, which means that the characteristics of the operating core simply depend on initial fuel loading. The baseline core is divided into three sections: starter, fertile, and reflector. The starter is the “critical” section of the reactor at beginning of life. It contains LEU to initiate criticality and provide excess neutrons for converting fertile to fissile materials in the fertile section. The core contains 85 fuel assemblies arranged in a hexagonal prism. Seventy-nine assemblies contain 91 fuel rods, each 2.7 m long by 20.5 mm in diameter. Six assemblies contain central voids for shutdown rod insertion. The clad is 1 mm thick β -SiC composite, which is highly resistant to both temperature excursions and neutron damage [33, 34]. The fuel is uranium carbide (UC) in the form of porous pellets. The interstitial pores allow room for fuel swelling and pathways for volatile fission products. The pellets are annular with a central hole that provides a means for volatile fission products to escape to a fission product collection system. This vented fuel in principle alleviates the pressure buildup and accommodates fuel swelling over the long core life.

The reflector consists of an inner section of canned Be₂C and an outer section of graphite. These reflector materials are highly neutron economic and keep the neutron leakage from the core under 2%. Due to power peaking around the core periphery, the starter fuel adjacent to the reflector has a reduced enrichment, leading to a radially flattened power profile that results in relatively uniform irradiation rates during the fuel cycle; this precludes the need for shuffling. Six rotatable drums are embedded in the reflector to provide reactivity control during normal operation.

4.2. Core Performance. The average fuel enrichment of the starter region is 11.4%, which results in an average fissile content of 6.1% over the whole core. The k_{eff} is shown in Figure 6, where the k_{eff} initially increases up to 1.023 due to ²³⁹Pu buildup in the starter region, and subsequently decreases due to ²³⁵U depletion and fission product buildup. As ²³⁹Pu also builds up in the converter region, k_{eff} decreases slowly after ~15 years.

The core performance is summarized in Table 1. The average discharge burnup is 145 GWd/t heavy metal (HM). The peak fuel burnup is 298 GWd/tHM for the starter fuel while the lowest fuel burnup is 48 GWd/tHM for the converter fuel located at the core edge region. The average fuel burnup of the starter and converter fuel is 192 and 95 GWd/tHM, respectively. The inlet temperature is 500°C and the temperature rise in the core is ~350°C. Under this condition, the peak fuel temperature is estimated to be 1490°C.

TABLE 1: Summary of EM² baseline core performance.

Reactor power	500 MW thermal
Fuel material	Uranium carbide
Clad/structure material	Silicon carbide
Coolant material	Helium
Cycle length	32 years
Average fissile content	6.1 wt%
Fuel loading	
Uranium	42.8 t
²³⁵ U	2.6 t
Fuel discharged	
Heavy metal	36.7 t
Uranium consumed	23%
Excess reactivity	2.0% δk
Peak/average burnup	285/135 GWd/t
Peak/average power density	165/58 W/cm ³
Peak/average fast fluence (>0.1 MeV)	7.9/3.7 $\times 10^{23}$ n/cm ²
System pressure	13.3 MPa
System pressure (depressurized)	0.45 MPa
Core pressure drop	25 kPa
Core inlet temperature	549°C
Core outlet temperature	850°C

TABLE 2: Isotopic inventory (kg) of EM² baseline core.

	Charge	10 years	20 years	30 years	Discharge
²³⁵ U	2,611	1,335	719	401	317
²³⁶ U	0	250	334	349	345
²³⁸ U	40,235	37,589	35,129	32,839	31,939
²³⁷ Np	0	27	57	77	83
²³⁹ Np	0	2	2	2	2
²³⁸ Pu	0	6	20	36	41
²³⁹ Pu	0	1,592	2,402	2,807	2,901
²⁴⁰ Pu	0	81	225	372	428
²⁴¹ Pu	0	50	94	127	138
²⁴² Pu	0	3	10	19	22
²⁴¹ Am	0	6	17	31	37
^{242m} Am	0	0	1	2	2
²⁴³ Am	0	0	1	2	2
²⁴² Cm	0	1	1	2	2
²⁴³ Cm	0	0	0	0	0
²⁴⁴ Cm	0	1	3	7	9
HM	42,846	40,942	39,016	37,073	36,271
Fuel	42,846	42,589	42,304	41,992	41,856

The fuel inventory as a function of time is summarized in Table 2. Fissile material burning and production are shown in Figure 7 for ²³⁵U and ²³⁹Pu. One of the design targets of the EM² is to promote much higher uranium utilization than that of the conventional power reactors. In the case of EM² once-through fuel cycle, the fissile uranium (²³⁵U)

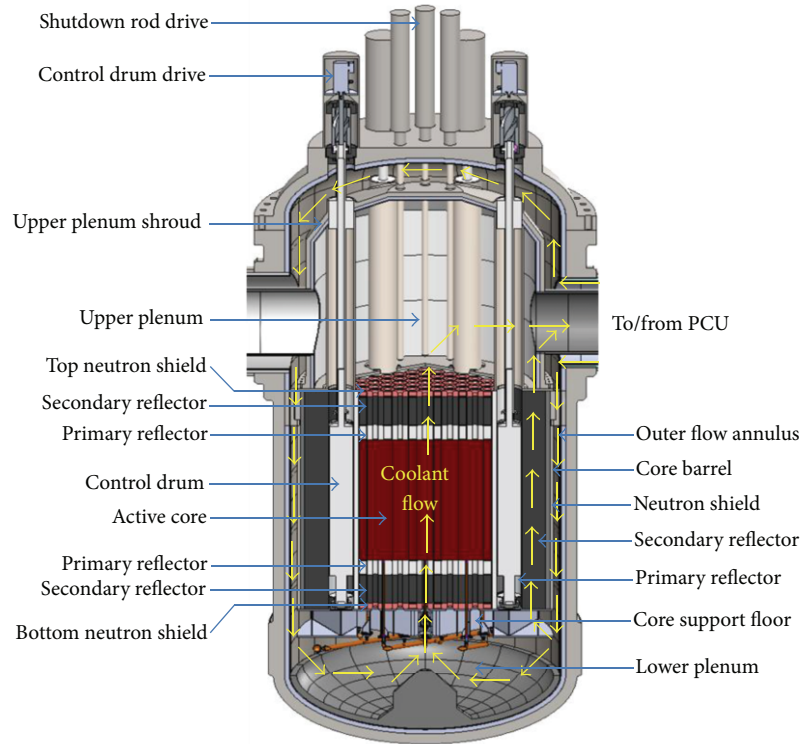
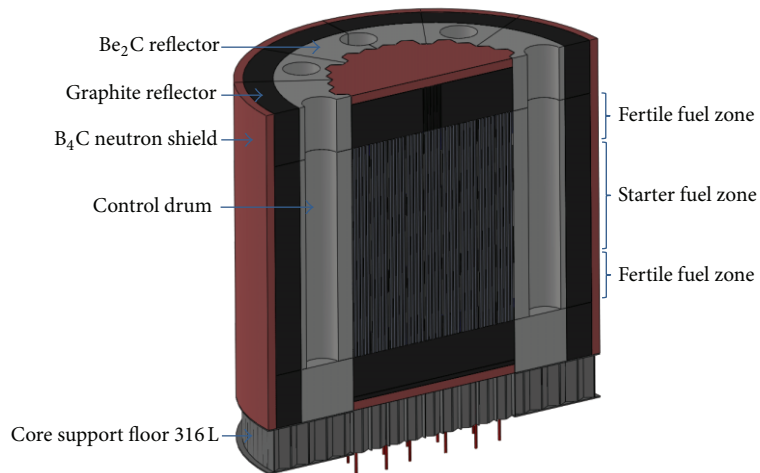
FIGURE 4: EM² reactor system.FIGURE 5: EM² baseline core region.

is appreciably burned at the end of cycle (EOC) with an average consumption rate of 88%, which was calculated based on initial loading and residual mass. The uranium was most effectively transmuted in the inner layer of the starter, resulting in the maximum consumption rate of 43% locally. The average uranium consumption over the whole core is 25%. Figure 8 compares the fission rates of uranium with those of other nuclides and shows that the fertile uranium (²³⁸U) contributes to the total fission rate by 18%.

The EM² core was designed to breed fissile plutonium and burn it. However, not all the fissile plutonium is burned at EOC and must be discharged. At EOC, the average fissile content (a fraction of ²³⁵U, ²³⁹Pu, and ²⁴¹Pu out of total heavy metal) is 9.4%. The amount of residual plutonium is 3.5 t, of which the fissile plutonium purity (a fraction of fissile plutonium out of total plutonium content) is 87%. This has a high fuel value and will be recycled in the subsequent fuel cycles without conventional reprocessing [35].

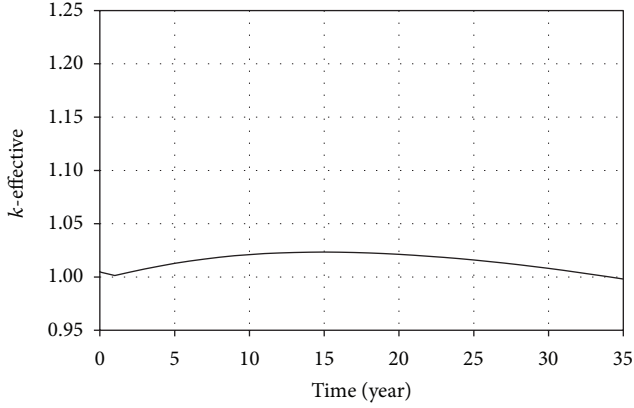

FIGURE 6: k_{eff} of EM² baseline core.

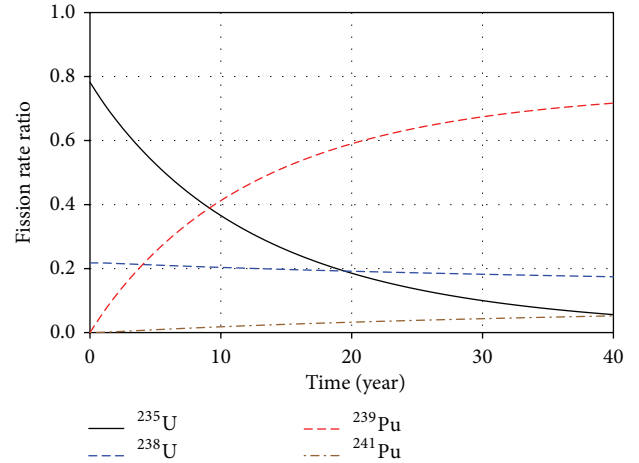

FIGURE 8: Fission rates of major nuclides.

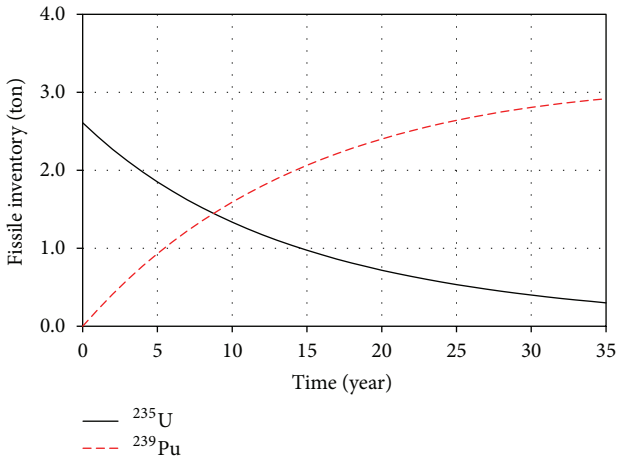

FIGURE 7: Fissile inventory change of EM² baseline core.

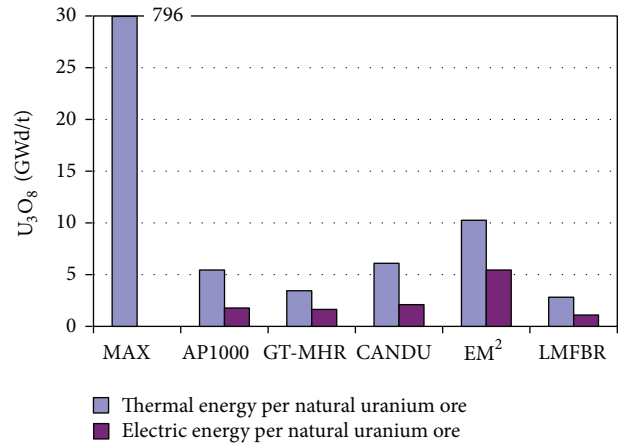

FIGURE 9: Comparison of energy per natural uranium ore.

TABLE 3: Comparison of mass flow for once-through fuel cycle.

	ALWR	EM ²
Comparative power output, MWe	1117	1117
Number of units	1	4.2
Refueling period, year	1.5	34
Number of batches	2.3	1
Fuel burnup, GWd/tHM	60	145
60-year operation		
(i) Heavy metal loading, ton	1522	318
(ii) Heavy metal discharge, ton	1425	270

4.3. *Fuel Cycle Characteristics.* The mass flow of the EM² baseline core is compared to that of an advanced LWR (ALWR) based on fuel management parameters summarized in Table 3 [36, 37]. The total electricity generation of EM² was normalized to 1117 MW, which requires 4.2 units of EM². For an operation period of 60 years, the amount of heavy metal loading and discharge is reduced by ~80% in the ultra-long EM² once-through fuel cycle when compared to ALWR once-through fuel cycle.

The energy production per natural uranium ore is shown in Figure 9 for various reactor types including ALWR, gas turbine modular helium reactor (GT-MHR), Canadian deuterium uranium (CANDU) reactor, and liquid metal fast breeder reactor (LMFBR) [38–40]. The maximum energy obtainable from 1 ton of natural uranium (U_3O_8) is estimated to be 796 GWd, if all uranium atoms fission and release 200 MeV per fission. The amount of thermal energy produced per ton of natural uranium is 10.3 GWd for the EM², while it is 5.4 GWd for the ALWR under the assumption that the fuel enrichment and fuel burnup are 4.8 wt% and 60 GWd/tHM, respectively.

The amount of high level waste (used nuclear fuel) generated per energy production is shown in Figure 10 for EM² and other reactors. The waste generation is the largest in the CANDU reactor due to the use of natural uranium fuel under a fully thermalized neutron spectrum. For the EM², the waste generation is 5.8 kgHM/GWd, while it is 15.6 kgHM/GWd for the ALWR.

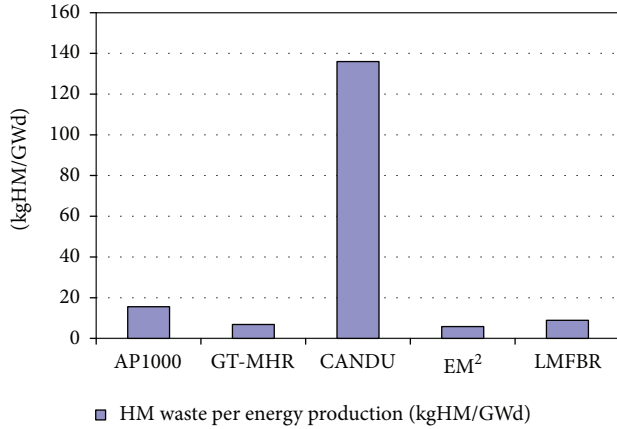

FIGURE 10: Comparison of waste per energy production.

TABLE 4: Comparison of unlevelized electricity costs.

	ALWR	EM ²
Number of cycles	20	1
Total electricity	270 TWh	66 TWh
Unit cost of fuel	~2,400\$/kgHM	~4,760\$/kgHM
Total fuel cost	1,600 M\$	200 M\$
Unlevelized average	~6\$/MWh	~3\$/MWh

4.4. Cost Estimation. Table 4 compares unlevelized electricity costs of EM² and ALWR. The fuel cost of EM² baseline core loading is estimated to be ~200 M\$ which includes uranium ore, conversion, enrichment, assembly structures, and fabrication costs. This fuel generates 66 TWh electricity over 30 years at a capacity factor of 95%. For the ALWR, total fuel cost is expected to be ~1600 M\$ for 30-year operation, including initial core loading. The corresponding total electricity generation will be 270 TWh over 30 years. Therefore, the EM² cycle yields a reduced fuel cycle cost when compared to the ALWR fuel cycle even though the unit fuel cost is expected to be higher for the EM² (~4,760 \$/kgHM on average) when compared to the ALWR fuel (~2,400 \$/kgHM) [41]. It is also worth noting that the fuel is an upfront capital charge in EM² as opposed to an operational charge in case of the ALWR.

A preliminary estimation of the electricity generation cost was made for EM² and other power plants such as ALWR, coal, and natural gas plants, and the results are shown in Figure 11. The assumptions and methodology used for the cost estimation are consistent with the Department of Energy (DOE) GEN IV International Forum cost estimating guidelines [42], and the cash flow methodology is from Du and Parsons [41]. Specifically, the pertinent assumptions used for cost calculations of the EM² and other technologies are as follows:

- (i) the EM² plant consists of 4 reactor modules, each with thermal rating of 500 MW, with a net plant efficiency of 53% and a capacity factor of 95%;

- (ii) ALWR plant consists of a 1,117 MWe net electric rating with a capacity factor of 92% averaged over the life of the plant;
- (iii) the costs are levelized over 60 years for the n th-of-a-kind plant;
- (iv) major financial parameters for nuclear and fossil fired plants include
 - (a) 50% debt at an 8% interest rate,
 - (b) 50% equity at a rate of 12%,
 - (c) general inflation of 2.5% per year;
- (v) enriched uranium cost is based on 95 \$/kg-U₃O₈ feed, 6 \$/kg-U₃O₈ conversion, and 165 \$/Separation Work Unit (SWU) enrichment.

It can be seen that EM² has a significant cost advantage over a comparable ALWR. It would break even with natural gas combined cycle plants at a natural gas price of 6-7 \$/MMBtu. The EM² cost advantage primarily comes from the compact equipment sizes, fewer components, significantly higher net plant efficiency, factory fabrication, and shorter field construction time. The EM² overnight capital cost is 3,800 \$/kWe versus 5,000–6,600 \$/kWe for ALWR plants. A single unit capacity addition is ~1 B\$ versus ~5 B\$ for ALWR. With the ability to add EM² units as power demand grows, the financial risk associated with an EM² plant substantially lower than a large ALWR can be achieved.

It should be noted that the uncertainty of the cost estimation is relatively large for the EM² when compared to the commercial power plant, because the materials and manufacturing technologies are still being developed for the fuel, clad, structural components, and auxiliary systems of the EM² while the market prices are well established for the commercial power plants.

5. Summary and Recommendations

The EM² is a 500 MW thermal GFR loaded with uranium carbide fuels, which satisfies physics design requirements of an ultra-long fuel cycle, high burnup, and compact reactor size, and is also economically competitive to large-scale commercial nuclear plants. These features offer new possibilities for fuel cycles to greatly improve fuel utilization and waste reduction, when compared to large-scale nuclear plants and other power sources. Nevertheless, there are many technical issues, which should be addressed and resolved through R & D activities as follows.

In particular, it is required to resolve uncertainties associated with fission product buildup during the ultra-long fuel cycle with low excess reactivity.

Transient and safety analyses are required to confirm the controllability of excess reactivity and local power peaking throughout the fuel cycle.

Experimental verifications are required for the core criticality and fuel irradiation along with thermal-fluid and mechanical integrity tests.

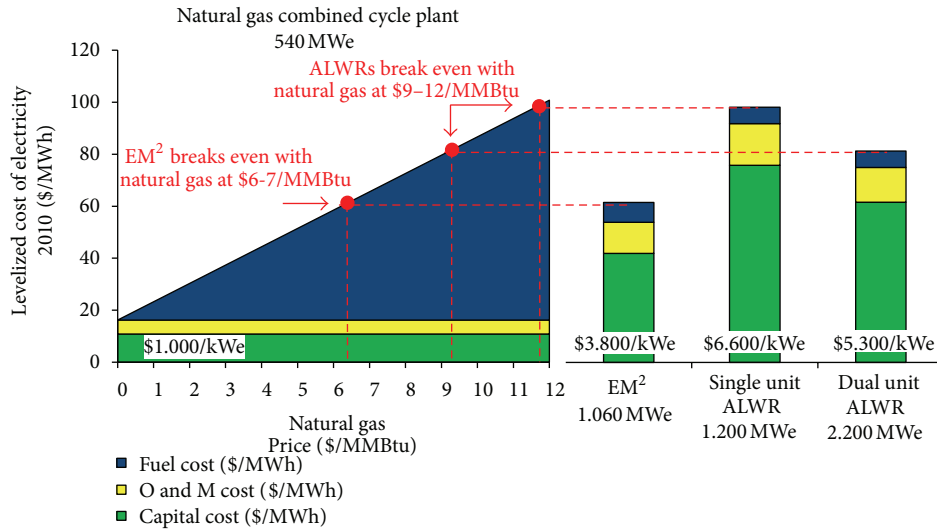

FIGURE 11: Comparison of EM² power cost versus other generating options.

Acknowledgment

This work was supported by General Atomics internal funding.

References

- [1] C. K. Paulson, "Westinghouse AP1000 electrical generation costs—meeting marketplace requirements," in *Proceedings of the International Congress on Advances in Nuclear Power Plants (ICAPP '02)*, Hollywood, Fla, USA, 2002.
- [2] "Innovative small and medium sized reactors: design features, safety approaches, and R&D trends," IAEA-TECDOC-1451, International Atomic Energy Agency, 2005.
- [3] *Report to Congress on Small Modular Nuclear Reactors*, U.S. Department of Energy, 2001.
- [4] *Design Features to Achieve Defense in Depth in Small and Medium Sized Reactors*, Nuclear Energy Series no. NP-T-2.2, International Atomic Energy Agency, 2009.
- [5] *Status of Innovative Small and Medium Sized Reactor Designs 2005: Reactors with Conventional Refuelling Schemes*, IAEA-TECDOC Series no. 1485, International Atomic Energy Agency, 2006.
- [6] R. L. Black, "Small modular reactor U.S. market and licensing possibilities," in *Proceedings of the American Nuclear Society Annual Meeting*, Atlanta, Ga, USA, June 2009.
- [7] *Status of Small Reactor Designs without On-Site Refuelling*, IAEA-TECDOC Series no. 1536, International Atomic Energy Agency, 2007.
- [8] D. J. Senior, C. L. Painter, K. J. Geelhood et al., "A new innovative spherical cermet nuclear fuel element to achieve an ultra-long core life for use in grid-appropriate LWRs," PNNL-16647, Pacific Northwest National Laboratory, 2007.
- [9] A. A. Belyaev, A. V. Kurachenkov, Y. K. Panov, and O. B. Samoilov, "Nuclear energy sources on the basis of integral reactors," *Nuclear Engineering and Design*, vol. 173, no. 1-3, pp. 131-141, 1997.
- [10] K. Hibi, H. Takimoto, M. Chaki, M. Matsuura, and K. Moriya, "Development of the package-reactor (1) -reactor for pioneering new nuclear markets," *Progress in Nuclear Energy*, vol. 47, no. 1-4, pp. 115-122, 2005.
- [11] M. Kambe, H. Tsunoda, K. Mishima, and T. Iwamura, "RAPID-L operator-free fast reactor concept without any control rods," *Nuclear Technology*, vol. 143, no. 1, pp. 11-21, 2003.
- [12] F. Sefidvash, "Status of the small modular fluidized bed light water nuclear reactor concept," *Nuclear Engineering and Design*, vol. 167, no. 2, pp. 203-214, 1996.
- [13] I. V. Dulera, A. Basak, P. P. Kelkar, and R. K. Sinha, "Compact high temperature reactor (CHTR)," in *Proceedings of the 16th Annual Conference of Indian Nuclear Society (INSAC '05)*, Mumbai, India, November 2005.
- [14] Z. Su'ud, "Advanced SPINNORs concept and the prospect of their deployment in remote area," in *Proceedings of the International Conference on Advances in Nuclear Science and Engineering (ICANSE '07)*, Bandung, Indonesia, November 2007.
- [15] Z. Su'ud and H. Sekimoto, "Preliminary design study of the ultra long life fast reactor," *Nuclear Engineering and Design*, vol. 140, no. 2, pp. 251-260, 1993.
- [16] M. Kawashima, K. Aoki, K. Arie, and Y. Tsuboi, "Neutronic feasibility of an LMFBR super long-life core (SLLC)," *Nuclear Engineering and Design*, vol. 106, no. 3, pp. 357-373, 1988.
- [17] T. K. Kim and T. A. Taiwo, "Feasibility study of ultra-long life fast reactor core concept," in *Proceedings of the Advances in Reactor Physics to Power the Nuclear Renaissance (PHYSOR '10)*, pp. 1756-1766, Pittsburgh, Pa, USA, May 2010.
- [18] J. Gilleland, C. Ahlfeld, D. Dadiomov et al., "Novel reactor designs to burn non-fissile fuels," in *Proceedings of the International Congress on Advances in Nuclear Power Plants (ICAPP '08)*, Anaheim, Calif, USA, June 2008.
- [19] A. E. Waltar and A. B. Reynolds, *Fast Breeder Reactors*, Pergamon Press, New York, NY, USA, 1981.
- [20] P. Yarsky, *Core design and reactor physics of a breed and burn gas-cooled fast reactor [Ph.D. thesis]*, Massachusetts Institute of Technology, 2005.

- [21] P. Wälti and P. Koch, "MICROX: a two-region flux spectrum code for the efficient calculation of group cross sections," General Atomic Report GA-A10827, Gulf General Atomic Company, 1972.
- [22] G. D. Joanou and J. S. Dudek, "GAM II, a B3 code for the calculation of fast neutron spectra and associated multigroup constants," General Atomic Report GA-4265, Gulf General Atomic Company, 1963.
- [23] G. D. Joanou, C. V. Smith, and H. A. Vieweg, "GATHER-II, an IBM-7090 code for the calculation of thermal neutron spectra and associated multigroup constants," General Atomic Report GA-4132, Gulf General Atomic Company, 1963.
- [24] C. A. Stevens and C. V. Smith, "GAROL: a computer program for evaluating resonance absorption including resonance overlap," Tech. Rep. GA-6637, Gulf General Atomic Company, 1965.
- [25] K. L. Derstine, "DIF3D: a code to solve one-, two-, and three-dimensional finite difference diffusion theory problems," Tech. Rep. ANL-82-64, Argonne National Laboratory, 1984.
- [26] R. Sherman, "PCBURP: a macroscopic cross section generation and nuclide depletion program for use with DIF3D," 21C024, General Atomics, 1996.
- [27] T. Nakagawa, H. D. Lemmel, and P. K. McLaughlin, "The JENDLE-3.3 fission-product data library," IAEA-NDS-138, International Atomic Energy Agency, 2003.
- [28] A. G. Croff, "A user's manual for the ORIGEN2 computer code," Tech. Rep. ORNL/TM-7175, Oak Ridge National Laboratory, 1980.
- [29] H. Choi, "Physics model of a gas-cooled fast reactor: review and assessment," in *Proceedings of the International Topical Meeting on Advances in Reactor Physics (PHYSOR '12)*, Knoxville, Tenn, USA, April 2012.
- [30] D. B. Pelowitz, Ed., "MCNPXTM user's manual," Tech. Rep. LA-CP-05-0369, Los Alamos National Laboratory, 2005.
- [31] J. Hou, K. Ivanov, and H. Choi, "MICROX-2 cross section library based on ENDF/B-VII," in *Proceedings of the International Topical Meeting on Advances in Reactor Physics (PHYSOR '12)*, Knoxville, Tenn, USA, April 2012.
- [32] J. Hou, K. Ivanov, and H. Choi, "Self-shielding models of MICROX-2 code," in *Proceedings of the International Conference on Mathematics and Computational Methods Applied to Nuclear Science & Engineering (M&C '13)*, Sun Valley, Idaho, USA, May 2013.
- [33] L. L. Snead, T. Nozawa, Y. Katoh, T. S. Byun, S. Kondo, and D. A. Petti, "Handbook of SiC properties for fuel performance modeling," *Journal of Nuclear Materials*, vol. 371, no. 1-3, pp. 329-377, 2007.
- [34] A. Kohyama, Y. Katoh, L. L. Snead, and R. H. Jones, "Development of SiC/SiC composite for fusion application," in *Proceedings of the 18th International Atomic Energy Agency Fusion Energy Conference*, Sorrento, Italy, October 2000.
- [35] H. Choi, D. W. McEachern, and R. W. Schleicher, "Energy Multiplier Module (EM²) recycling fuel cycles," in *Proceedings of the 1st Annual ANS SMR Conference*, Washington, DC, USA, October-November 2011.
- [36] W. E. Cummins, M. M. Corletti, and T. L. Schulz, "Westinghouse AP1000 advanced passive plant," in *Proceedings of the International Congress on Advances in Nuclear Power Plants (ICAPP '03)*, Cordoba, Spain, May 2003.
- [37] "Westinghouse—AP1000," Technology Fact Sheet, Westinghouse, 2008.
- [38] C. Ellis, A. Baxter, and A. Shenoy, "Modular helium reactor fuel cycle concepts and sustainability," in *Proceedings of the 2nd International Topical Meeting on High Temperature Reactor Technology (HTR '04)*, Beijing, China, September 2004.
- [39] "Design manual: CANDU 6 generating station physics design manual," Wolsong NPP 2 3 4, 86-03310-DM-000 Rev. 1, Korea Atomic Energy Research Institute/Atomic Energy of Canada Limited, 1995.
- [40] J. J. Duderstadt and L. J. Hamilton, *Nuclear Reactor Analysis*, John Wiley & Sons, New York, NY, USA, 1976.
- [41] Y. Du and J. E. Parsons, "Update on the cost of nuclear power," 09-004, Center for Energy and Environmental Policy Research, 2009.
- [42] "Cost estimating guidelines for Generation IV nuclear energy systems, Revision 4.2," GIF/EMWG/2007/004, Generation IV International Forum, 2007.